



**VERITEK**

# EARTH LEAKAGE RELAY (LCD)



**VIPS 98L**

## FEATURES

- (1) Leakage Current Display (Auto Ranging)
- (2) User Settable Trip Level and Time Delay
- (3) Password Protection
- (4) Bar graph display in percentage of set value
- (5) Two Relays
- (6) CBCT Open Circuit Detection
- (7) Auto / Manual Reset User Programmable
- (8) Power ON Delay User Programmable
- (9) User Programmable Auto Reset Time in case of Auto Reset Mode

## APPLICATION

- Generator Control Panel
- Distribution Control Panel
- Protection Control Panel

## VERITEK ENGINEERING PVT. LTD.

Plot No. 222, EL-Electronic Zone, MIDC, TTC Industrial Area,  
 Mahape, Navi Mumbai - 400701, India  
 Tel. : +91-22-2762 1125 / 6529 4268  
 Email : sales@veritekindia.com | Web : www.veritekindia.com

## MECHANICAL DIMENSION

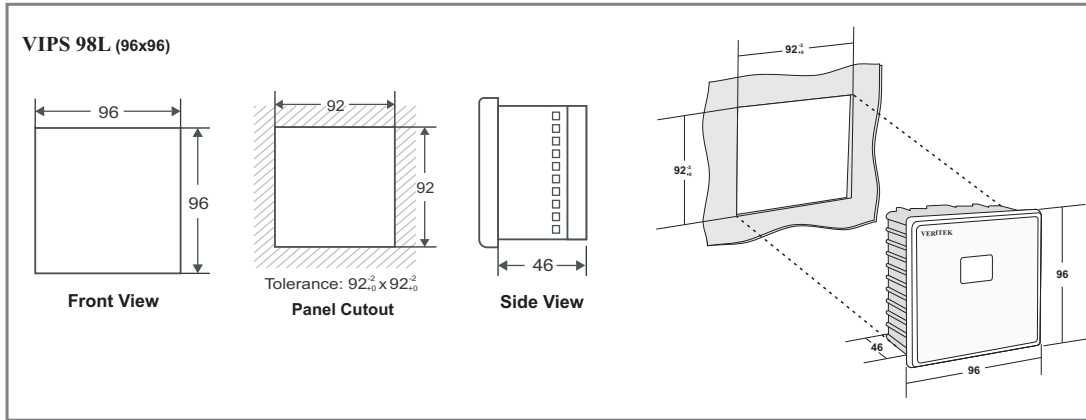

## MOUNTING ARRANGEMENT

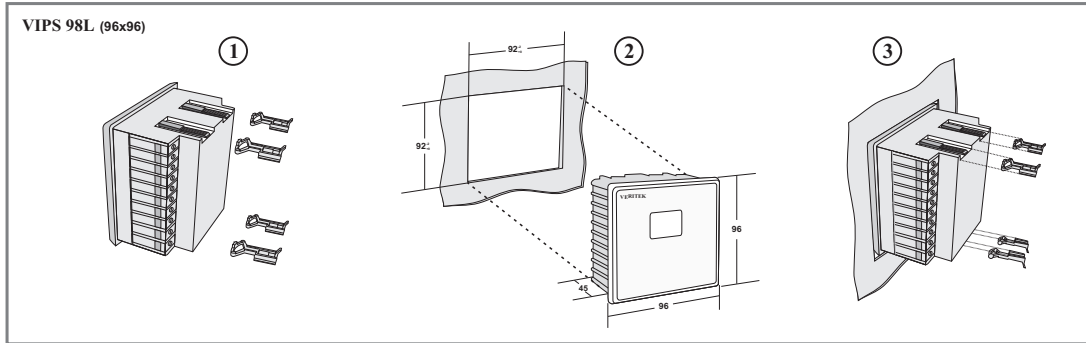

## CONNECTION DETAILS (ONLY FOR CBCT)

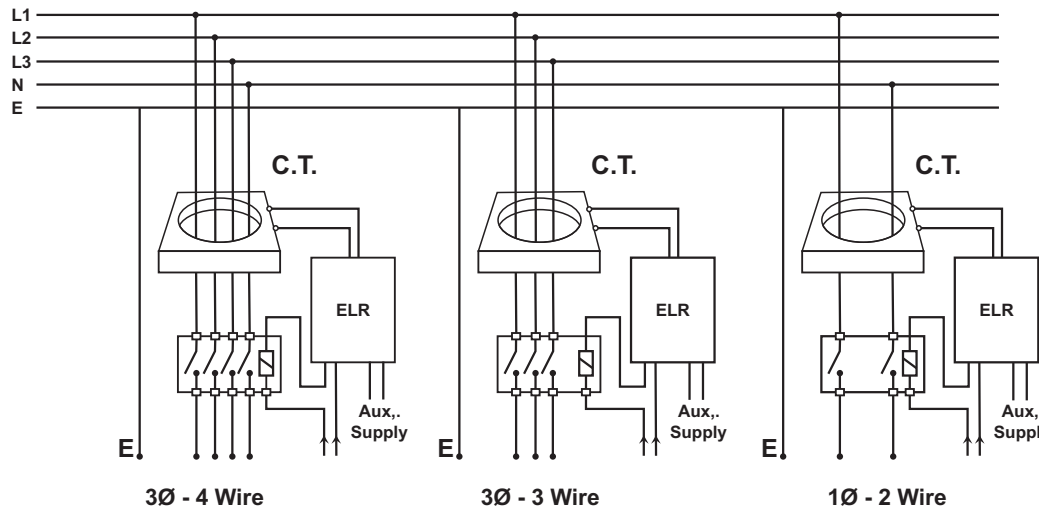

## CONNECTION DETAILS

### Electrical Wiring / Connection Diagram

VIPS 98L (1 Phase 2 Wire)

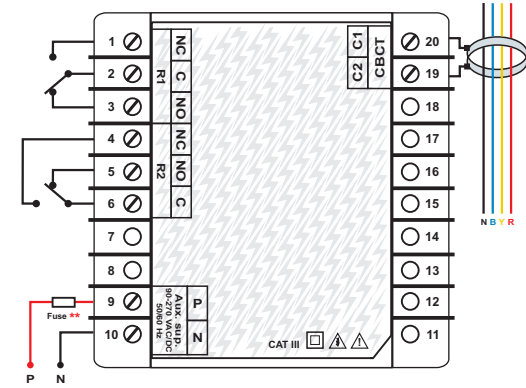

## SPECIFICATION

- Sensing** : Through CBCT  
35/70/120/210mm ID (any other circular & rectangular size on request)
- Aux. Supply** : 90 - 270 VAC / DC, 50/60Hz
- Burden on Supply** : < 3 VA
- Display** : LCD display (actual value of leakage current)
- Delay** : 0(<25mS for Fault current>5xIth) to 10 sec.
- Set Point** : 10mA up to 30 Amps
- Accuracy** : ± 5% of set point, ± 2 counts
- Relay Contacts** : 2 Potential Free Contact (NO, C & NC), (energise or de-energise on trip programmable)
- Contact Rating** : 6 Amps / 230 VAC / 28 VAC
- Temperature** : Operating : - 10°C to 55°C  
Storage : - 20°C to + 75°C
- Humidity** : < 95% RH (non condensing)
- Dimension** : 96 x 96 x 48 mm (L x W x D)
- Mounting** : Flush Mounting with side clamps
- Weight** : 250 gm

## KEYPAD SETUP

### Keys Description

	<b>TEST / UP Key</b> A) To Test Relay Contact B) To edit values C) To move in between Menus or Sub-Menus
	<b>ESC / SIDE / RESET Key</b> A) Escape from Sub-Menu to Menu / Menu to Operational Mode B) Move from one digit to another C) Manual Reset button in case of Trip
	<b>PROGRAMMING Key</b> A) To enter into programming mode B) To enter into particular Menu / Sub-Menu C) To save particular Value

## MENU / SUB-MENU DESCRIPTION

MENUS	SUB-MENUS
<b>RL 1</b> Setting for relay 1	<b>ALM</b> To set Alarm <b>INS</b> To select Instantaneous Trip <b>MOD</b> To change Relay Operation Mode Normally Energised(NC) or De-energised(NO) <b>RST</b> To change option for Relay Auto / Manual Reset <b>HYS</b> To set Hysterises Value
<b>TM 1</b> Setting for Time delay of relay 1	<b>dEL</b> To set Delay Value <b>REC</b> To set Recovery Time for Auto Reset Mode <b>POW</b> To set Power ON Delay
<b>RL 2</b> Setting for relay 2	<b>FUN</b> To set function type for Relay 2 <b>PRE</b> To set Pre-Alarm Value <b>MOD</b> To change Relay Operation Mode Normally Energised(NC) or De-energised(NO) <b>RST</b> To change option for Relay Auto / Manual Reset <b>HYS</b> To set Hysterises Value
<b>TM 2</b> Setting for Time delay of relay 2	<b>dEL</b> To set Delay Value <b>REC</b> To set Recovery Time for Auto Reset Mode
<b>PWd</b> Setting for Password	<b>Ed</b> To set Enable / Disable Password <b>SET</b> To set New Password
<b>RST</b>	Reset all settings

## PROGRAMMING

<b>UST</b>		Press Program Key
<b>200</b>		Set 200 Password (Default Factory Password)
<b>YA</b>		To enter into programming mode
<b>RL 1</b>		Press Program Key to set Relay 1 Setting
<b>ALM</b>		Press Program Key to set Alarm
<b>1A / 10A / 30A</b>		To select range (1A, 10A, 30A) set value <small>(0-999 mA) (1-9.99 A) (10-30 A)*</small> * To Set Tripping Points
<b>INS</b>		Press Program Key to select Instantaneous Trip
<b>ON / OFF</b>		To select ON or OFF
<b>MOD</b>		Press Program Key to set Relay Operation Mode
<b>ON / OFF</b>		To set ON Normally Energised or OFF Normally De-energised
<b>RST</b>		Press Program Key to set the option for Relay Reset
<b>MAN / AUT</b>		To set Manual or Auto Reset
<b>HYS</b>		Press Program Key to set Hysteresis Value
<b>03</b>		To set value (3% to 25%)
<b>YA</b>		To Switch from RL1 to TM1
<b>TM 1</b>		Press Program Key to set Time Setting for Relay 1
<b>dEL</b>		Press Program Key to set delay value
<b>990</b>		To set value (0.0 to 99.9 sec.)
<b>REC</b>		Press Program Key to set Recovery Time
<b>005</b>		To set value (0.0 to 99.9 sec.)
<b>POW</b>		Press Program Key to set Power ON Delay
<b>990</b>		To set value (0.0 to 99.9 sec.)
<b>YA</b>		To Switch from TM1 to RL2
<b>RL 2</b>		Press Program Key to set Relay 2 Setting
<b>FUN</b>		Press Program Key to set Function Type for Relay 2
<b>PRE / RL 1</b>		To set from Pre-Alarm to same as Relay 1
<b>PRE</b>		Press Program Key to set Pre-Alarm
<b>50</b>		To set from 50% to 90%
<b>MOD</b>		Press Program Key to set Relay Operation Mode
<b>ON / OFF</b>		To set ON Normally Energised or OFF Normally De-energised
<b>RST</b>		Press Program Key to set the option for Relay Reset
<b>MAN / AUT</b>		To set Manual or Auto reset
<b>HYS</b>		Press Program Key to set Hysteresis Value
<b>03</b>		To set value (3% to 50%)

<b>YA</b>		To Switch from RL2 to TM2
<b>TM 2</b>		Press Program key to set Time Setting for Relay 2
<b>dEL</b>		Press Program key to set delay value
<b>990</b>		To set value (0.0 to 99.9 sec.)
<b>REC</b>		Press Program key to set Recovery Time
<b>005</b>		To set value (0.0 to 99.9 sec.)
<b>YA</b>		To Switch from TM2 to PWD
<b>PWd</b>		Press Program key for Password Settings
<b>Ed</b>		Press Program key to Enable or Disable Password
<b>EN / DIS</b>		To set to Enable or Disable Password
<b>SET</b>		Press Program key to set New Password
<b>000</b>		To set Password
<b>YA</b>		To Switch from PWD to RST
<b>RST</b>		Press Program key to Reset all Settings
<b>SUR</b>		Press Program key to Reset to Factory set values

**INS** : When INS ON is selected the delay will become zero (Irrespective of set delay) in case leakage current is x5 times of set value

**FUN** : In this setting the relay 2 can either be configured same as relay 1 or as PRE alarm. When FUN is set as RL1 then all setting of RL1 will be automatically copied to relay 2 & the system will be have as 2C/O relay.

## PRINCIPLE OF OPERATION

The unit employs a CBCT (Core Balance Current Transformer) to sense the Leakage Current. In a healthy system the Vector sum of the currents flowing in the 3 Phases is Zero. But in case of an Earth Fault / Leakage the vector sum is not Zero & a resultant current begins to flow. This is sensed and converted into an analog Voltage signal which is compared with a preset reference value. In case of 3 Phase 4 Wire system Neutral also has to be passed through the CBCT.

## CORE BALANCE CURRENT TRANSFORMER ( CBCT )

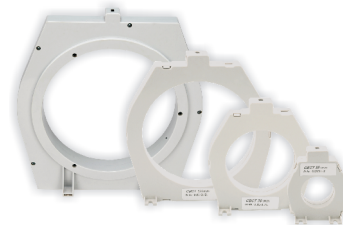

## SIZES AVAILABLE

VIPS CBCT 35, 70, 120, 210, 310 mm ID

\* Note : Any other ID / rectangular CBCT available on request

## SAFETY PRECAUTIONS :

All safety related codifications, symbols and instructions that appear in this operating manual or on the equipment must be strictly followed to ensure the safety of the operating personnel as well as the instrument.

If the equipment is not used in a manner specified by the manufacturer it might impair the protection provided by the equipment.

If there is physical damage to the unit then do not use it.

Read complete instruction prior to installation and operation of the unit.

## WIRING GUIDELINES :

### Warning

1) To Prevent the risk of electric shock power supply to the equipment must be kept OFF while doing the wiring arrangement.

2) Wiring shall be done strictly according to the terminal layout with shortest connection. Conform that all connection are correct.

### CAUTION :



1) To ensure the safe operation of unit, check the wiring and connections.

## TEST CERTIFICATE

Type : **EARTH LEAKAGE RELAY (VIPS 98L)**  
Nominal Current IN : 10mA to 30A  
Accuracy : Class 1

Aux.Supply
90 / 270V AC/DC, 50/60Hz

Range : 10mA to 30A

CBCT DIA :

Accuracy Test :

Tripping Observed Between 50-90% of set value / same as trip relay

**Found OK**

**Note :**

A) For Digital Readouts the error is Computed in Counts.

- Class 1.0 =  $\pm 1\%$  of Full Scale  $\pm 1$  Count

- Class 0.5 =  $\pm 0.5\%$  of Full Scale  $\pm 1$  Count

**Tested By :**

**Date :**